

MACHINE SPECIFICATION



Item / Model			Vturn-V300
Capacity	Swing over bed	mm	600
	Max. turning dia.	mm	540
	Max. turning length	mm	190(ID.) 500(OD.)
	Std. turning dia.	mm	450
Travels	X axis stroke	mm	400
	Z axis stroke	mm	520
Spindle	Max. spindle speed	rpm	2500 (opt.3500)
	Spindle nose	mm	A2-8
	Spindle bore	mm	86
	Inner bearing	mm	130
	Chuck diameter	inch	12" (opt.10")
Turret	No. of tools	no.	8
	Tool shank size	mm	32
	Max. boring bar dia.	mm	50
	Exchange time	sec	1 (hydraulic)
Feedrate	Rapid feedrate	m/min	X:15, Z:24
	Cutting feedrate	mm/min	X/Z=0~1260
Motor	Spindle motor	kW	15/18.5 (α P30i)
	X/Z axis servo motor	kW	X: 4, Z: 4
Coolant	Tank capacity	L.	170
	Controller	FANUC	0i-T
Machine	LxWxH(chip conveyor included)	mm	1560x2970(3235)x2918
	Net weight	kg	6000
	Power requirement	kVA	40

Standard accessories

- 12" solid chuck with soft jaws
- Chip conveyor with cart
- Automatic forced lubrication
- Fully enclosed splash guarding
- Tool holders (exch VDI tooling)
- 3 step warning light
- Fanuc 0i-T control

Optional accessories

- 10" hydraulic solid chuck
- Air blow system
- Bigger spindle motor 18.5/22 kW (α P 40i)
- Detachable chip conveyer (to reduce the floor space when cleaning)
- Renishaw tool presetter (detachable)
- High pressure coolant
- Auto door
- VDI turret
- C axis and VDI turret
- Fanuc 21i-T /18i-T control
- Higher outlet chip conveyer

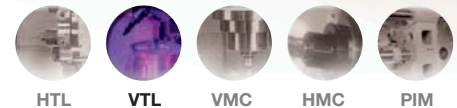
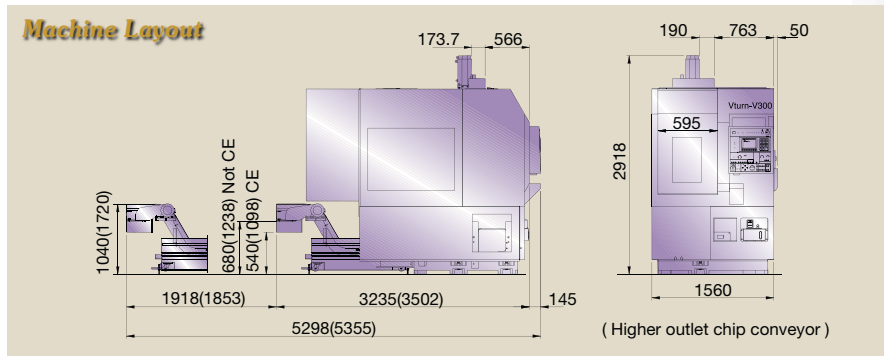

TAIWAN

http://www.or.com.tw
E-mail : info@mail.or.com.tw
Victor Taichung Machinery Works Co; Ltd.

Headquarters:

266, Sec.3 Taichung Kan Rd.
Taichung, Taiwan, R.O.C.
TEL : 886-4-23592101
FAX : 886-4-23592943

Overseas Marketing Division:

TEL : 886-4-23580701
FAX : 886-4-23584541

UK

Victor Europe Limited
TEL : 44-1-706-648485
FAX : 44-1-706-648483

FRANCE

Victor France
TEL : 33-1-64772000
FAX : 33-1-64772063

GERMANY

Victor GmbH
TEL : 49-2261-478434
FAX : 49-2261-478327

SOUTH AFRICA

Victor Fortune (PTY) Ltd
TEL : 27-11-3923800
FAX : 27-11-3923899

MALAYSIA

Victor Machinery (M) SDN. BHD.
TEL : 60-3-56337180
FAX : 60-3-56337191

THAILAND

Victor (Thailand) Co. Ltd.
TEL : 66-2-9263735
FAX : 66-2-9032373

USA

Fortune International Inc.
TEL : 1-732-2140700
FAX : 1-732-2140701

CHINA

Zhongtai Precision Machinery (Tianjin)
TEL : 86-22-25321592
FAX : 86-22-25321663
JIANRONG PRECISION Machinery (Shanghai)
TEL : 86-21-59768018
FAX : 86-21-59768008