

# Machine Specifications

ITEM \ MODEL		VTplus-15 VTplus-20	Vturn-16 Vturn-20	Vturn-26 Vturn-26/110	Vturn-36/85 Vturn-36/125	Vturn-40/220	Vturn-46/165
<b>MACHINE CAPACITY</b>							
Swing over bed	mm	500	450	520	650	780	820
Std. Turning dia.	mm	190	160	290	445	520	520
Max. turning dia.	mm	260	230	380	550	620	730
Swing over carriage	mm	265	300	350	500 (475 for VDI)	620	520
Center distance	mm	420 405	635	650 1130	890 1290	2165	1750
<b>AXIS FEEDS</b>							
X axis travel :							
-Std turret	mm	130+20	115+20	190+50	275+30	310+30	365+25
-VDI turret		93+87	110+80	126+130	143+217	-	137+303
-VDI turret, C-axis		-	-	-	156+199	-	186+234
Z axis travel	mm	320	600	610 1090	855 1255	2200	1650
Rapid feed - X/Z axis	m/min	24 / 24	12 / 15 (Opt. 20 / 24)	12 / 15	12 / 15	20 / 20	12 / 15
Feed motor - X/Z axis	KW	1.6 / 1.6	1.6 / 3	3 / 3	3 / 4	4 / 7	3 / 4 (Opt. 3 / 7)
Cutting federate	mm/min	0~1260	0~1260	0~1260	0~1260	0~1260	0~1260
Ball screw dia x pitch	mm	32xP12 (X) 40xP12 (Z)	28xP6 (X) 40xP10 (Z)	30xP6 (X) 40xP10 (Z)	36xP6 (X) 50xP10 (Z)	36 x P10 (X) 50 x P10 (Z)	36 x P6 (X) 50 x P10 (Z)
<b>SPINDLE</b>							
Spindle nose (chuck)	inch	A2-5 (6") A2-6 (8")	A2-5 (6") A2-6 (8")	A2-8 (10")	A2-8 (12") (A2-11 for LSB)	A2-11 (15")	A2-11 (15")
Max. spindle speed	rpm	6000 4200	6000 4200 (Opt. 3500)	3500 (Opt. 2500)	2500 (Opt.2000)	2500	1500
Spindle motor power	KW	5.5/7.5 7.5/9.0	7.5 / 9.0	15 / 18.5 (Opt. 18.5/22)	22 / 26 With gearbox	30 / 37 With gearbox	30 / 37 With gearbox
Bearing inside dia.	mm	90 100	90 100	130 (160 for LSB)	160 (220 for LSB)	160	180
Spindle bore	mm	52 62	52 62	87 (105 for LSB)	105 (160 for LSB)	105	123
Hole through draw bar	mm	40 52 (66 for LSB)	40 52	75 (91 for LSB)	91 (80 for CV,160 for LSB)	91	110
<b>TURRET</b>							
No. of tools	no.	12 8	12 10 (Opt. 8)	10	10 (12 for CV)	10 (Opt. 12)	10 (12 for CV)
No. of live tools	no.	-	-	-	6	-	6
Tool shank size	mm	20 25	20 20 (Opt. 25)	25	32	32	32
Max. boring bar dia.	mm	32 (VDI-30) 40 (VDI-30)	32 (VDI-30) 40 (VDI-40)	50 (VDI-40)	50 (VDI-50)	50 (VDI-50)	60 (VDI-50)
Exchange time (T-T)	sec	1	1	1	1	1	1
Milling speed	rpm	-	-	-	2500	-	2500
Milling motor	kW	-	-	-	7.0	-	7.0
<b>TAILSTOCK</b>							
Quill dia.	mm	75	75	110	110	150	150
Quill stroke	mm	80	80	100	100	150	150
Quill taper		MT#4	MT#4	MT#4	MT#4	MT#5	MT#5
<b>OTHER</b>							
CNC controller (FANUC)		0i-TC	0i-TC	0i-TC	0i-TC	0i-TC	0i-TC
Tank capacity	L.	110	87	100 130	130 150	450	250
Approx. machine size	m	2.2 x 1.6 x 1.75	3.3 x 1.5 x 1.65	3.8 x 1.7 x 2 4.4 x 1.7 x 2	4.7 x 2 x 2.2 5.2 x 2 x 2.2	6.7 x 2.1 x 2.2	6.2 x 3 x 2.5
Net weight	kg	3800 3800	4000 4000	5400 6000	8000 9100	14000	13500

※Machine and controller specifications are subject to change without notice.

## Standard Accessories

- Kitagawa® hydraulic chuck with soft jaws
- Programmable tailstock  
(Optional for VTplus-15 & 20 with manual tailstock)
- Chip conveyor with cart  
(Optional for VTplus-15 & 20)
- Automatic forced lubrication
- Fully enclosed splash guarding
- Tool holders (excl. VDI turret system)
- Fanuc 0i-T control
- 3 step warning light
- Air conditioner for electrical cabinet

## Optional Accessories

- Hard jaws
- Tailstock center
- Manual tool presenter
- Automatic tool presenter
- Parts catcher
- High pressure coolants
- Auto door
- Air blow system
- Oil-mist remover
- Bar feeder interface
- Steady rest (Manual or hydraulic)
- C-axis with live tooling (CV) for Vturn-36 / 46
- VDI turret
- 12" chuck/3000rpm for Vturn-26
- Bigger chuck on Vturn-36 / 40 / 46



# Vturn Machine Layout

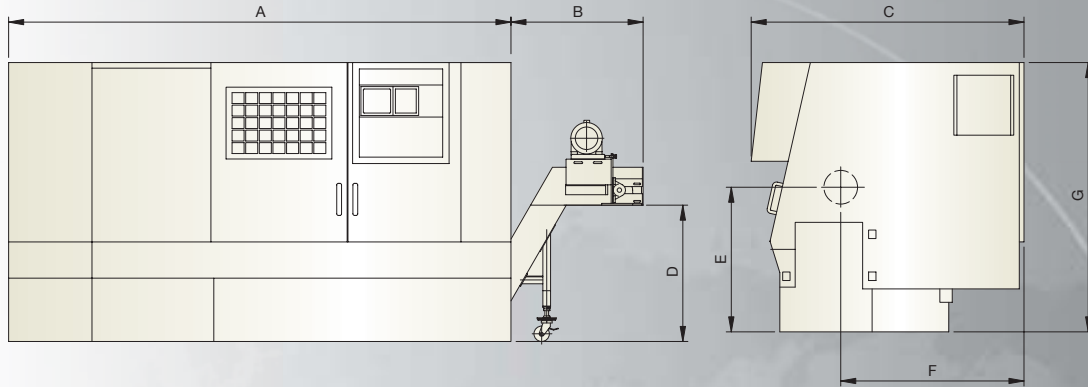

ITEM \ MODEL	Vturn-16 Vturn-20	Vturn-26 Vturn-26/110	Vturn-36/85 Vturn-36/125	Vturn-40/220	Vturn-46/165
A	2540	3020 3600	3640 4140	5633	5180
B	750	750	1070	1207+460 move out	1030
C	1500	1745	1985	2404	2167
D (CE mark)	800 (563)	855 (678)	1100 (994)	1271 (1100)	1065 (899)
E	900	960	1108	1201	1165
F	1050	1175	1352	1453	1364
G	1650	1940	2205	2313	2515



**VTplus-20 with gantry robot**



**Vturn-36W for wheel turning**



**Vturn-V300 vertical lathe**



**THE VICTOR-TAICHUNG COMPANIES**

## TAIWAN

<http://www.or.com.tw>

E-mail : [info@mail.or.com.tw](mailto:info@mail.or.com.tw)

- Victor Taichung Machinery Works Co; Ltd.

### Headquarters:

266, Sec.3 Taichung Kan Rd.  
Taichung, Taiwan, R.O.C.  
TEL : 886-4-23592101  
FAX : 886-4-23592943

### Overseas Marketing Division:

TEL : 886-4-23580701  
FAX : 886-4-23584541

## UK

- Victor Europe Limited  
TEL : 44-1-706-648485  
FAX : 44-1-706-648483

## FRANCE

- Victor France  
TEL : 33-1-64772000  
FAX : 33-1-64772063

## GERMANY

- Victor GmbH  
TEL : 49-2261-478434  
FAX : 49-2261-478327



### VictorTaichung profile:

Sales turnover: USD 177.2 mil's (in 2006)\*

No. of employees: 977

\*Exchange rate: 1 USD=32 TWD.



HTL



VTL



VMC



HMC



PIM

## SOUTH AFRICA

- Victor Fortune (PTY) Ltd  
TEL : 27-11-3923800  
FAX : 27-11-3923899

## MALAYSIA

- Victor Machinery (M) SDN. BHD.  
TEL : 60-3-56337180  
FAX : 60-3-56337191

## THAILAND

- Victor (Thailand) Co. Ltd.  
TEL : 66-2-9263735  
FAX : 66-2-9032373

## USA

- Fortune International Inc.  
TEL : 1-732-2140700  
FAX : 1-732-2140701

## CHINA

- Zhongtai Precision Machinery (Guangzhou)  
TEL : 86-20-82264885  
FAX : 86-20-82264861
- JIANRONG PRECISION Machinery (Shanghai)  
TEL : 86-21-59768018  
FAX : 86-21-59768008